

Steering Intermediate Shaft Rattle Noise

Service Category Steering

Section Steering Column

Market USA

Toyota Supports
 ASE Certification 

Applicability

YEAR(S)	MODEL(S)	ADDITIONAL INFORMATION
2005 – 2012	Tacoma	Body Type(s): Access Cab, Double Cab, Regular Cab, Double Cab Long Bed Drive Type(s): 2WD, 4WD VDS(s): JU4GN, JU62N, KU4HN, KU72N, LU42N, LU4EN, MU4FN, MU52N, NX4GN, NX62N, PX42N, PX4EN, TU4GN, TU62N, TX4GN, TX62N, UU42N, UU4EN, UX42N, UX4EN WMI(s): 3TM, 5TE, 5TF

SUPERSESSION NOTICE

The information contained in this bulletin supersedes SB No. T-SB-0119-10.

- Applicability has been updated to include 2012 model year Tacoma vehicles.

Service Bulletin No. T-SB-0119-10 is Obsolete and any printed versions should be discarded. Be sure to review the entire content of this bulletin before proceeding.

Introduction

Some 2005 – 2012 model year 4WD Tacoma and 2WD Tacoma PreRunner vehicles may exhibit steering rattle noise when driven over rough road surfaces. A newly designed steering intermediate shaft has been made available to address this condition.

Warranty Information

OP CODE	DESCRIPTION	TIME	OFF	T1	T2
ST1007	R & R Intermediate Shaft	1.2	45220-04010	91	40

APPLICABLE WARRANTY

- This repair is covered under the Toyota Comprehensive Warranty. This warranty is in effect for 36 months or 36,000 miles, whichever occurs first, from the vehicle's in-service date.
- Warranty application is limited to occurrence of the specified condition described in this bulletin.

Steering Intermediate Shaft Rattle Noise

Parts Information

PREVIOUS PART NUMBER	CURRENT PART NUMBER	PART NAME	QTY
45220-04010	45220-04020	Shaft Assy, Steering Intermediate	1
90080-11555	Same	Bolt, w/Washer	2

Repair Procedure

NOTE

Prior to removing the steering intermediate shaft, make sure the steering wheel and front wheels are straight and remain stationary. Once the intermediate shaft is removed, do NOT allow the steering wheel to spin freely. Use a steering wheel holder to keep the steering wheel from turning.

1. Confirm the noise complaint and confirm that the intermediate shaft is the source of the noise.
2. Install a steering wheel holder.
3. Remove the steering column hole cover by disengaging the 4 clips.

Figure 1.

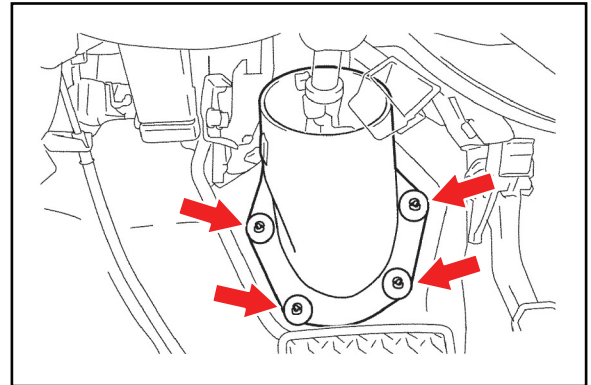

Steering Intermediate Shaft Rattle Noise

Repair Procedure (Continued)

4. Put matchmarks on the intermediate shaft.

Figure 2.

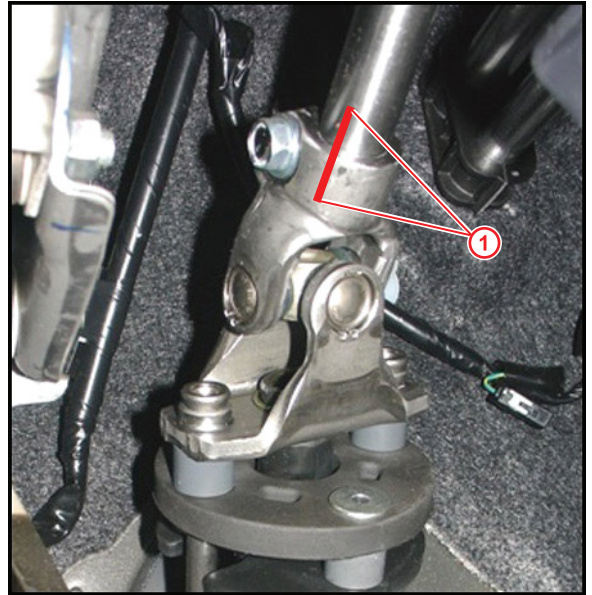

1	Matchmarks
----------	-------------------

5. Remove the one bolt that attaches the intermediate shaft to the steering column and discard the bolt.

Figure 3.

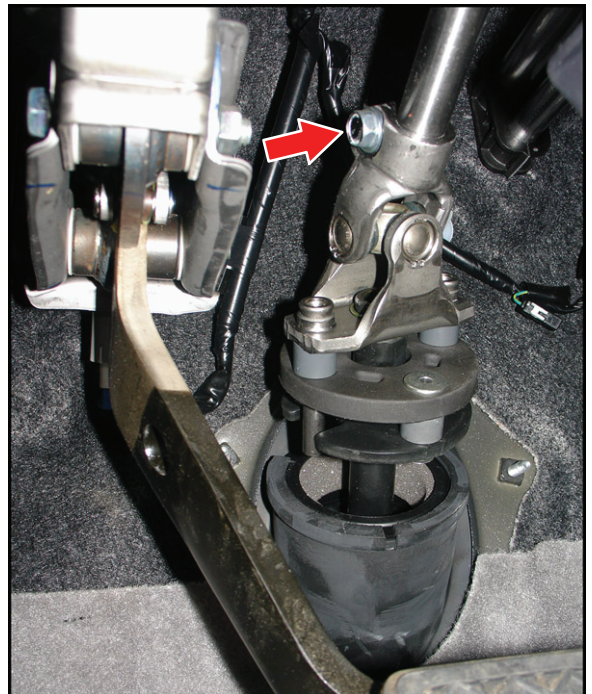

Steering Intermediate Shaft Rattle Noise

Repair Procedure (Continued)

6. Access the intermediate shaft from the driver's side engine cover and remove the 2 clips that hold the engine cover.

Figure 4.

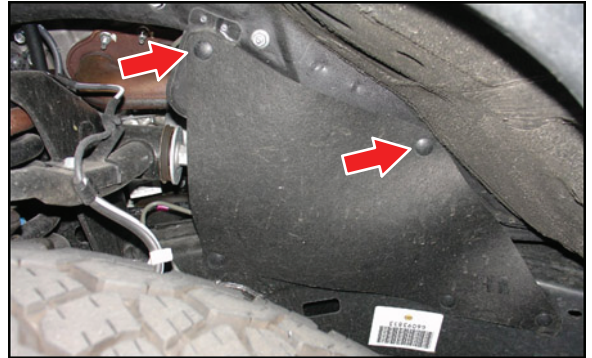

7. Put matchmarks on the intermediate shaft as shown.

Figure 5.

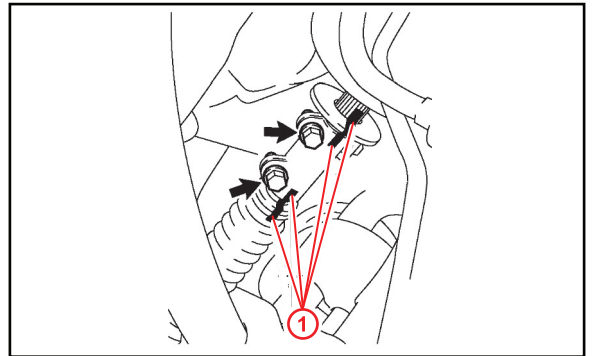

1	Matchmarks
----------	-------------------

8. Remove the upper bolt that attaches the intermediate shaft No. 1 to the intermediate shaft No. 2 and discard the bolt.

Loosen the lower bolt, then slide the shaft up and out.

Figure 6.

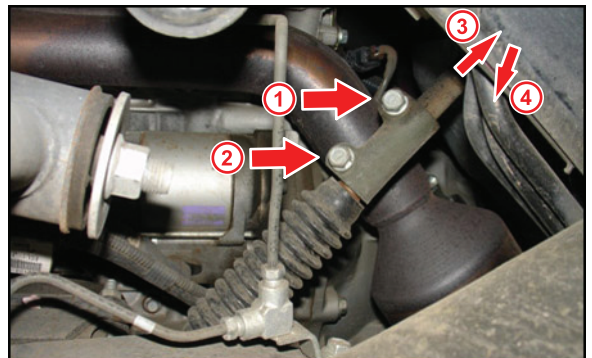

1	Upper Bolt
2	Lower Bolt
3	Slide Intermediate Shaft Up
4	Slide Intermediate Shaft Out

Steering Intermediate Shaft Rattle Noise

Repair Procedure (Continued)

9. Place matchmarks on the NEW intermediate shaft.

Figure 7.

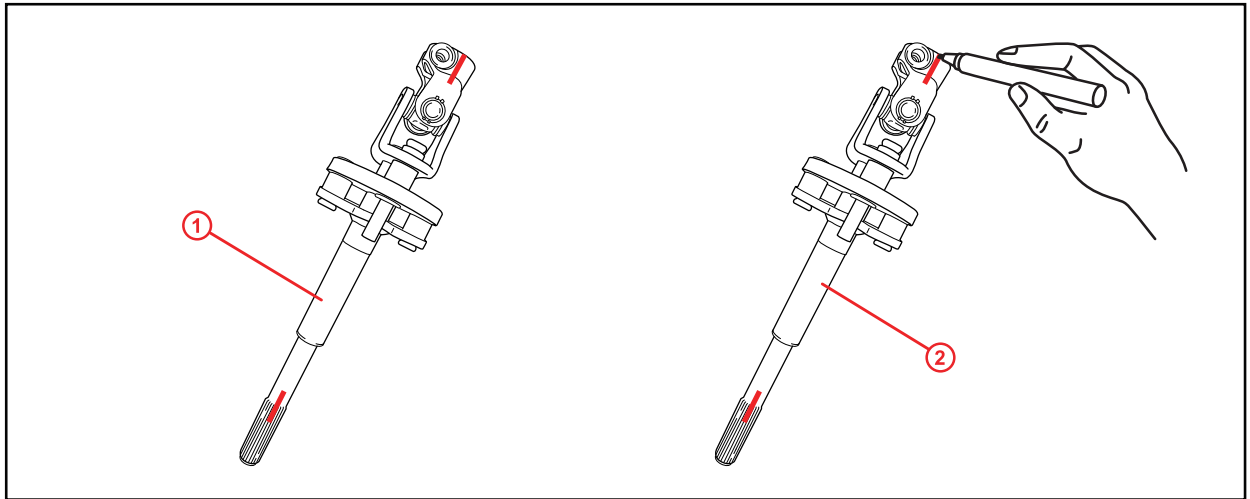

1 Original No. 2 Steering Intermediate Shaft

2 New No. 2 Steering Intermediate Shaft

- A. Place the NEW steering intermediate shaft next to the original intermediate shaft.
 - B. Transfer the matchmarks on the original intermediate shaft to the same locations on the NEW steering intermediate shaft.
10. Install the NEW steering intermediate shaft.

- A. Align the matchmarks and install the intermediate shaft to the steering column first.
- B. Align the matchmarks and install the intermediate shaft to the lower intermediate shaft.

NOTICE
 Make sure the intermediate shaft is in the correct position when installing.

Figure 8.



1	Slide Intermediate Shaft Into Column First
2	Slide Intermediate Shaft Into Lower Shaft Second

Steering Intermediate Shaft Rattle Noise

Repair Procedure (Continued)

11. Install the NEW bolt.
Torque: 35 N*m (357 kgf*cm, 26 ft*lbf)

Figure 9.

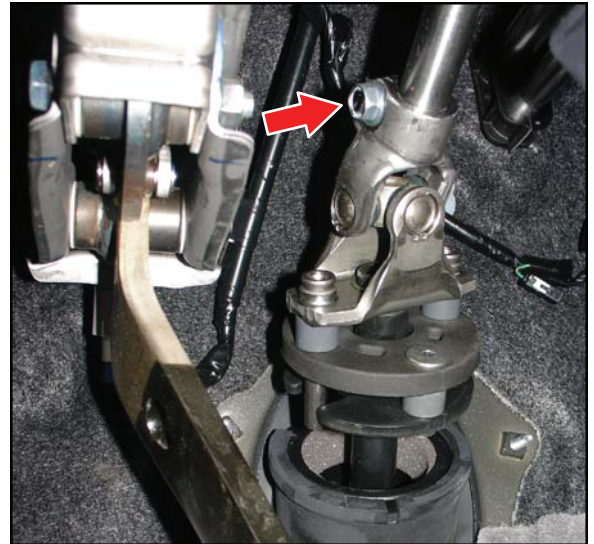

NOTICE

- Please ensure that the splined portion of the shaft is completely seated into the U-joint female end.
- When installing the bolt, make sure the groove in the shaft is aligned properly so that the bolt will prevent the shaft from sliding out of the U-joint.

Figure 10. INCORRECT: Splines Are Showing – Not Installed Completely



Figure 11. CORRECT: Splines Are Not Showing



Steering Intermediate Shaft Rattle Noise

Repair Procedure (Continued)

12. Install the NEW upper bolt and reuse the lower bolt.

Figure 12.

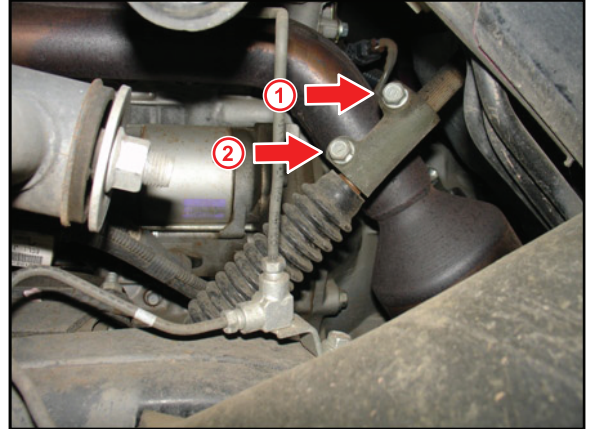

1	New Upper Bolt
2	Reuse Lower Bolt

13. Tighten the 2 intermediate shaft bolts. (See Figure 12.)
Torque: 35 N*m (357 kgf*cm, 26 ft*lbf)
14. Install the engine cover with the 2 clips.

Figure 13.

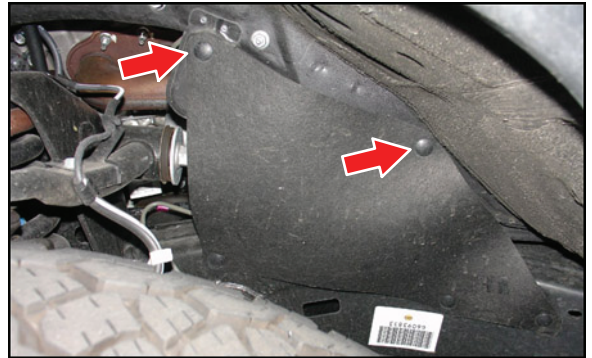

Steering Intermediate Shaft Rattle Noise

Repair Procedure (Continued)

15. Install the column hole cover with the 4 clips.

Figure 14.

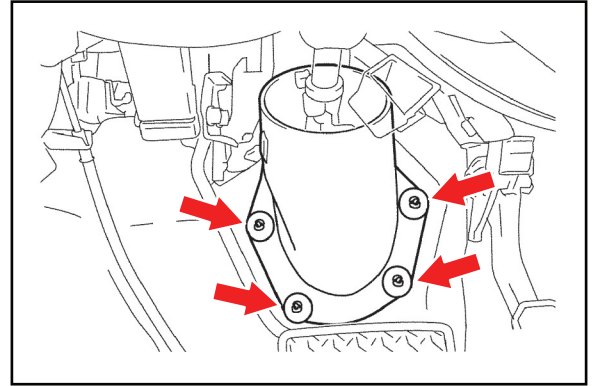

16. Remove the steering wheel holder from the vehicle.
17. Road test the vehicle to verify the repair. Confirm that the steering wheel is centered and no warning lights illuminate during the test drive.
18. If the steering wheel is not centered, follow the Repair Manual steering wheel centering procedure.

Refer to the Technical Information System (TIS), applicable model year Tacoma Repair Manual:

- [2005](#) Tacoma:
Steering – Steering Column – “Steering System: Repair”
 - [2006](#) / [2007](#) / [2008](#) / [2009](#) / [2010](#) / [2011](#) / [2012](#) Tacoma:
Steering – Steering Column – “Steering Column: Steering System: Repair”
19. Perform calibration of the yaw rate sensor and steering angle sensor.

NOTE

Any time alignment is performed, calibration of the yaw rate and steering angle sensor is necessary.

Refer to TIS, applicable model year Tacoma Repair Manual:

- [2005](#) Tacoma:
Brake – Brake Control/Dynamic Control System – “ABS With EBD & BA & TRAC & VSC System: Calibration”
- [2006](#) / [2007](#) / [2008](#) Tacoma:
Brake – Brake Control/Dynamic Control System – “Brake Control: Vehicle Stability Control System: Calibration”

Steering Intermediate Shaft Rattle Noise

Repair Procedure (Continued)

- [2009](#) / [2010](#) / [2011](#) / [2012](#) Tacoma:
Brake – Brake Control/Dynamic Control System – “Brake Control: Vehicle Stability Control System (for Hydraulic Brake Booster): Calibration”
20. Test drive the vehicle to confirm that the noise is gone.